

# REF. 120.2

Hydromassage lounger in stainless steel  
 AISI 316L (Marine quality). Polish finish.  
 Support included.

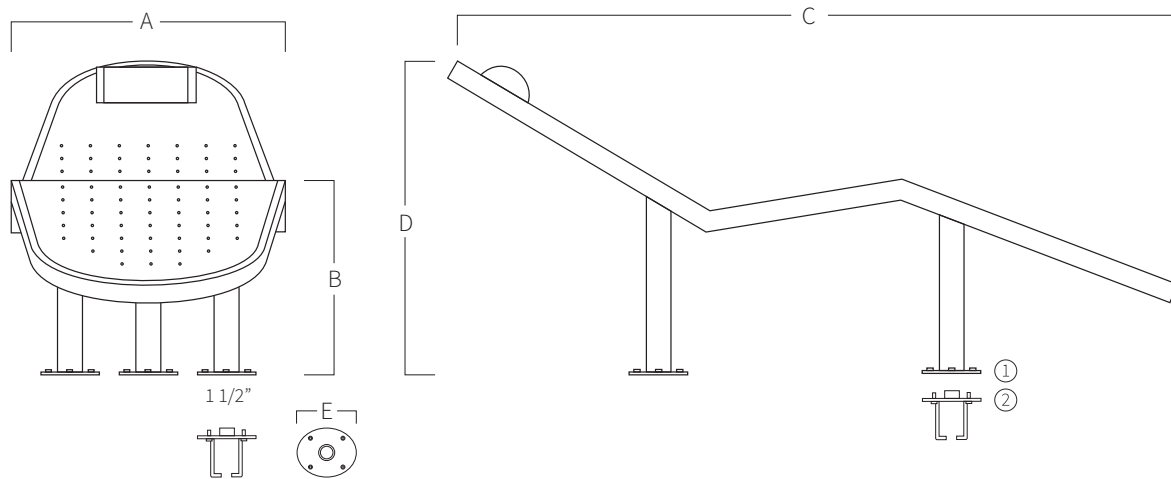

A	B	C	D	E
700	480	1850	785	Ø150

Measure in mm

- ① Nuts to fix lounger to the support (12 units).
- ② Support to embed at ground level.

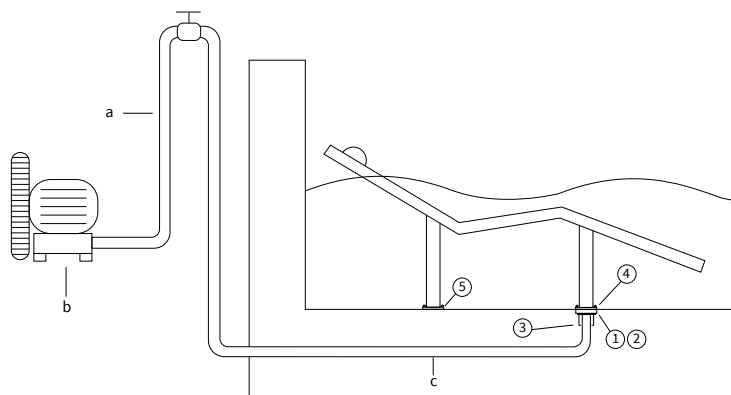

## MOUNTING SYSTEM

- 1) Connect the air intake to the support.
  - 2) Fix the earth connection.
  - 3) Embed the support to get the platen to remain at ground level.
  - 4) Fix the lounger to the support with the nuts (included).
  - 5) Fix the other two legs to the ground level with plugs and screws (not included).
- a) Tube Ø75mm.  
 b) Blower pump:  
 Curve 140 - 1,3kw - 216 m<sup>3</sup>/h (Ref. AQA-SKS-250).  
 c) Connexion tube 1 1/2".

\*Pneumatic or electric button to be defined in work.