

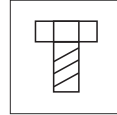

# REF. 120.4L

Double liner hydromassage in stainless steel  
AISI 316L (Marine quality). 1 gasket included.



Screws  
Included



Earth  
Connection

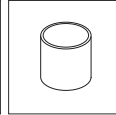

1 1/2"

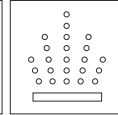

Air

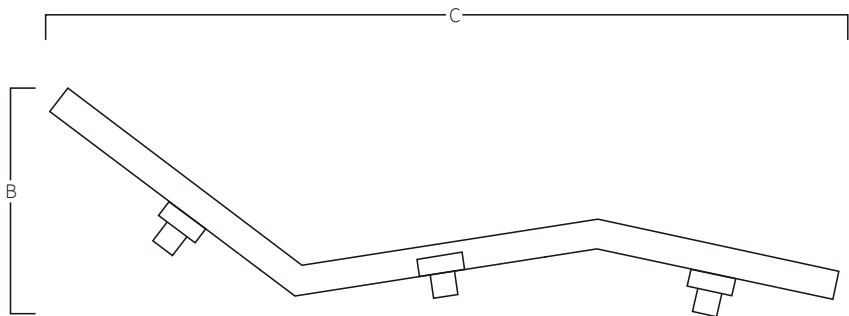
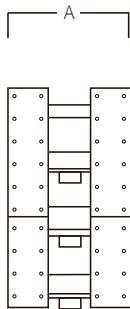

A	B	C
372	420	1685
14,65	16,54	66,34

Measures in mm  
Measures in inch

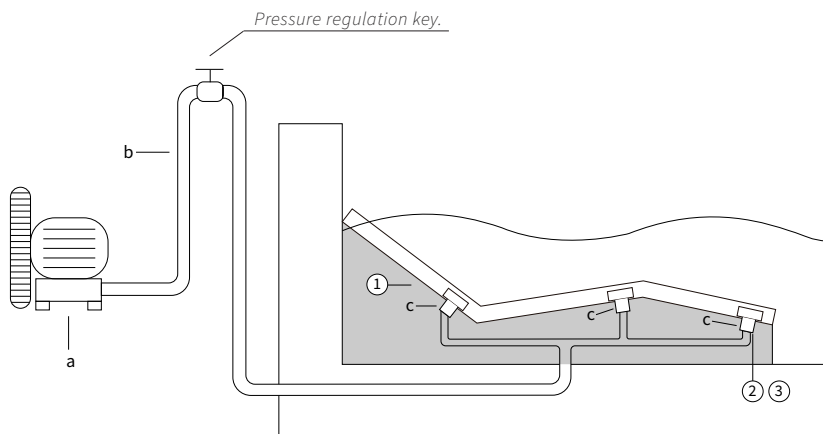

## MOUNTING SYSTEM

- 1) Connect the three 1 1/2" female fitting to the air intake.
- 2) Fix the earth connection.
- 3) Embed the main structure to the wall designed to be that, place the gasket and fix the registrable cover.

a) Blower pump:

120L.4 - 1,1kw - 210m<sup>3</sup>/h (Ref. AQA-S1100-210).

b) Tube Ø75mm.

c) Connection 1 1/2" female fitting.

\*Pneumatic or electric button to be defined in work.