

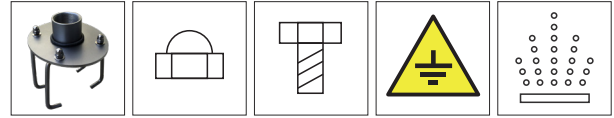

## REF. 138

Semi-circular hydromassage shower in stainless steel AISI 316L (Marine quality). Polished finish.



Support included

Nuts included

Screws included

Earth connection

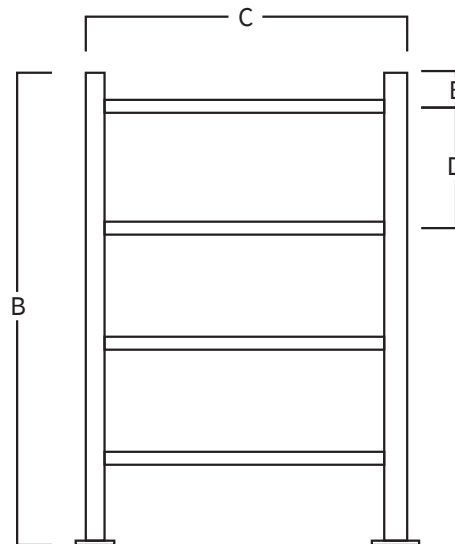
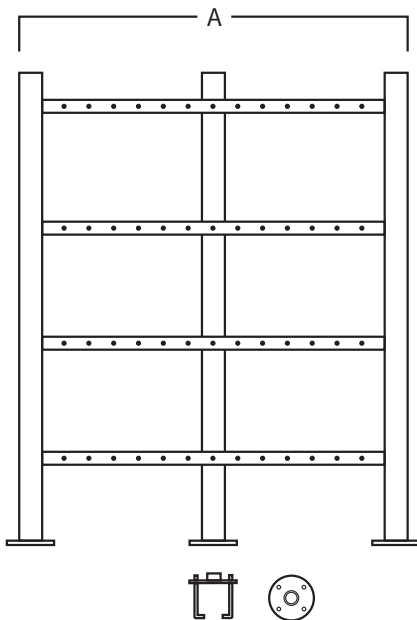

A	B	C	D	E
1000	1100	800	250	100

Measures in mm

### MOUNTING SYSTEM

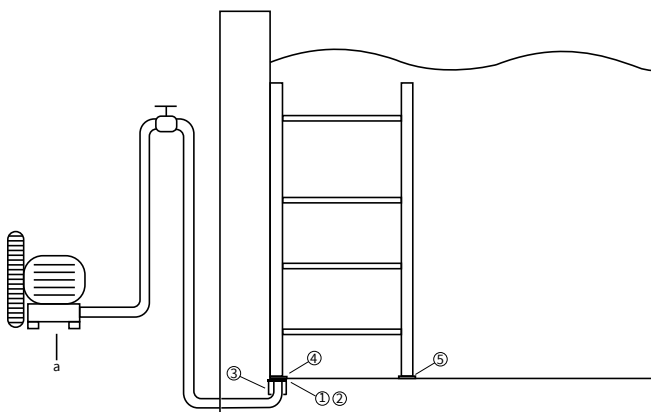

- 1) Connect the air intake to the support.
- 2) Fix the earth connection.
- 3) Embed the support to get the platen to remain at ground level.
- 4) Fix the structure with the nuts.
- 5) Fix the other two legs to the ground level with the plugs and screws (included).
  - a) Tube Ø75mm.
  - b) Blower pump:  
138: 1,1kw - 210 m<sup>3</sup>/h (Ref. AQA-S1100-210).
  - c) Connexion tube 1 1/2 ".

\*Pneumatic or electric button to be defined in work.