



# REF. AF-8

Waterfall in stainless steel AISI 316L  
(Marine quality) and fiberglass structure.  
Polished finish.



Support  
Included



Earth  
Connection

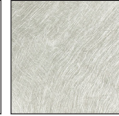

Fiberglass



Red



White

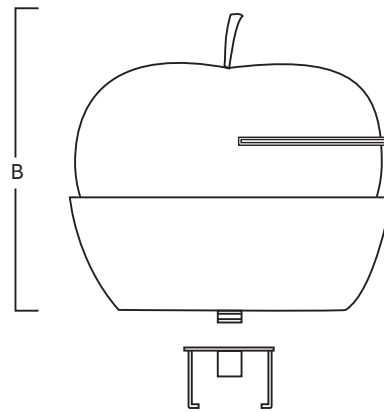
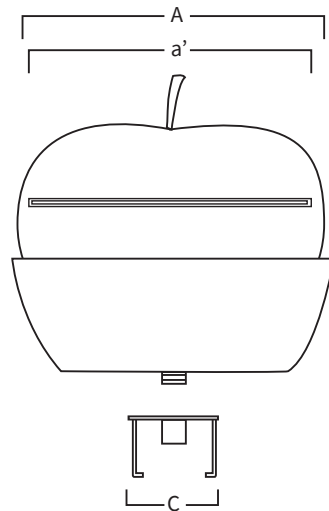

A	a'	B	C
450	400	440	Ø190
17,72	15,75	17,32	Ø07,48
mm inch			

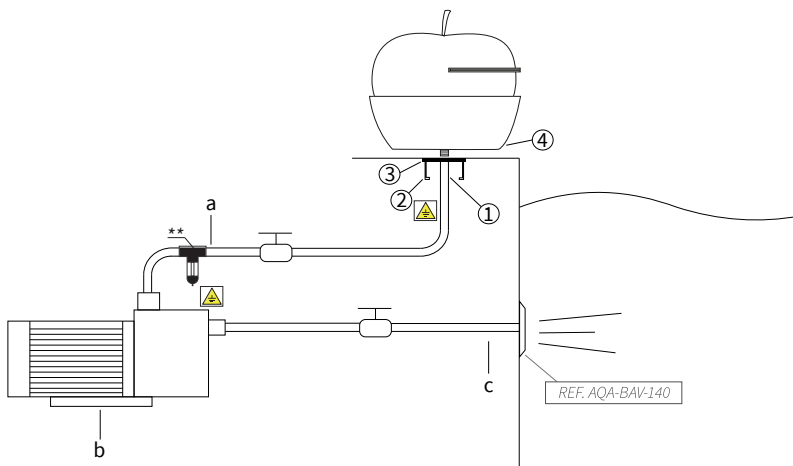

## **MOUNTING SYSTEM**

- 1) Connect the water intake to the support with 1 1/2" female fitting.
- 2) Fix the earth connection to the support.
- 3) Embed the support to get the platen at ground level.
- 4) Screw the structure.
  - a) Impulsion tube 2" (Ø63mm).
  - b) Self-priming pump:  
AF-8: 1hp - 17,3m<sup>3</sup>/h (Ref. AQA-B17).
  - c) Suction tube 2" (Ø63mm).

\*Pneumatic or electric button to be defined in work.

\*\*AQA recommends to install a POOL PROTECTOR, to avoid corrosion of the existing stainless steel elements in the pool.