

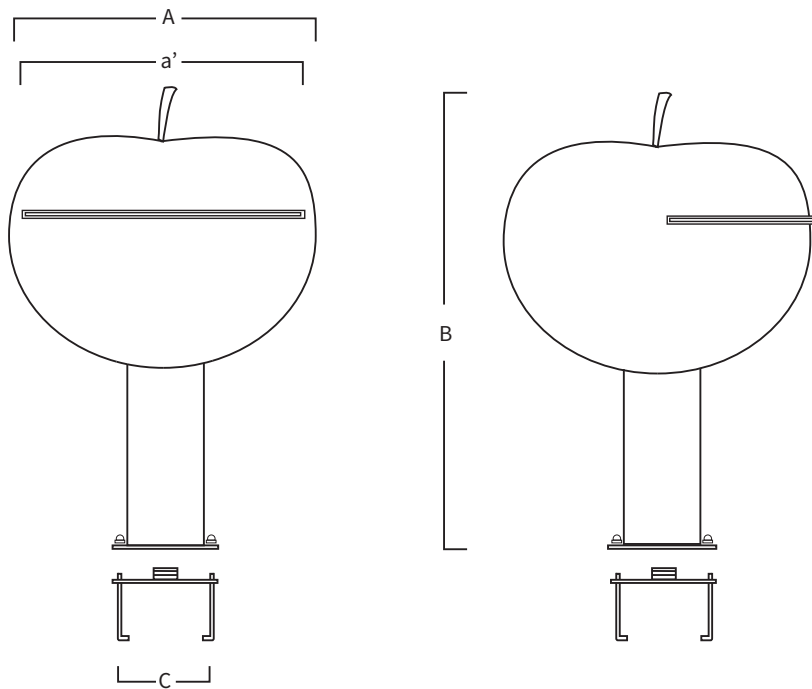

REF. AF-11.1

Waterfall with base in stainless steel AISI 316L (Marine quality) and fiberglass structure. Polished finish.



A	a'	B	C
450	400	870	Ø190
17,72	15,75	34,25	Ø07,48
mm inch			

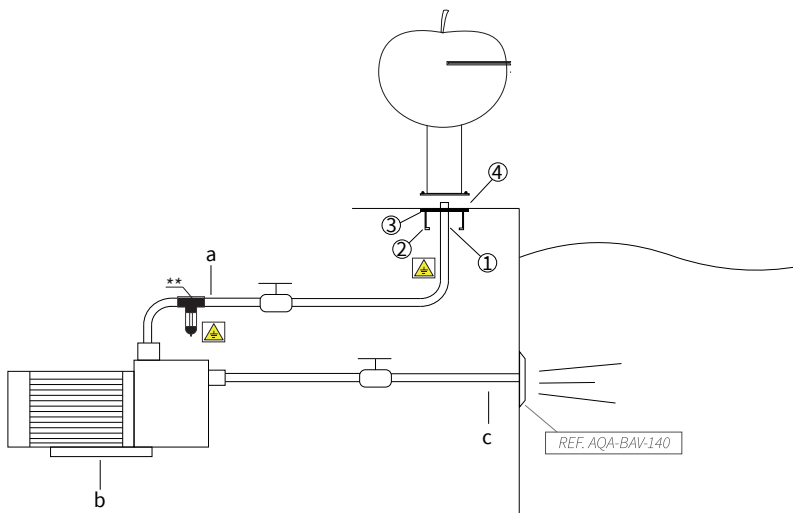

MOUNTING SYSTEM

- 1) Connect the water intake to the support with 1 1/2" female fitting.
- 2) Fix the earth connection to the support.
- 3) Embed the support to get the platen at ground level.
- 4) Fix the structure with the nuts (included).
 - a) Impulsion tube 2" (Ø63mm).
 - b) Self-priming pump:
AF-11.1: 1hp - 17,3m³/h (Ref. AQA-B17).
 - c) Suction tube 2" (Ø63mm).

*Pneumatic or electric button to be defined in work.

**AQA recommends to install a POOL PROTECTOR, to avoid corrosion of the existing stainless steel elements in the pool.