



REF. AF-1

Waterfall in stainless steel AISI 316L (Marine quality). Polished/satin finish.



Support Included

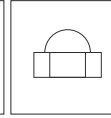

Nuts Included



Earth Connection

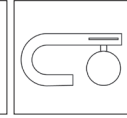

Left Side

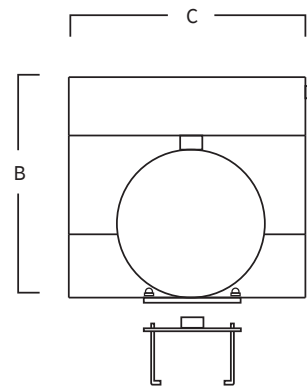
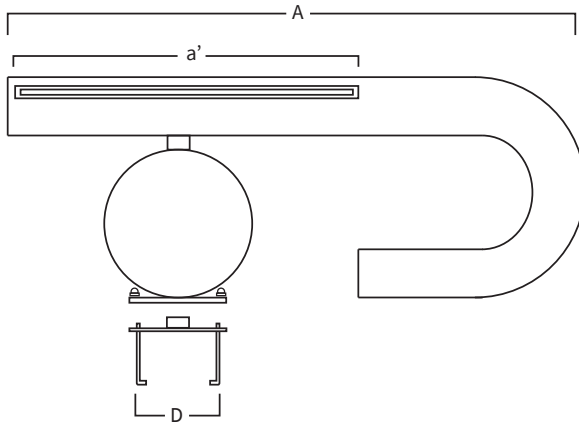

A	a'	B	C	D
1030	500	385	360	Ø180
40,55	19,69	15,16	14,17	Ø07,09
mm inch				

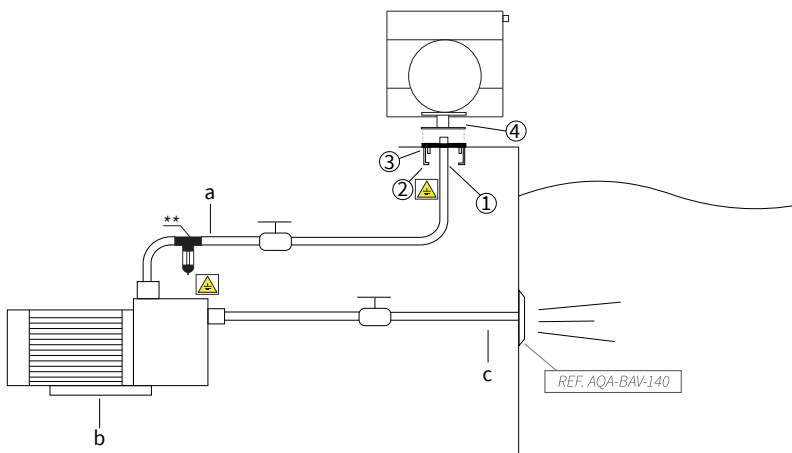

MOUNTING SYSTEM

- 1) Connect the water intake to the support with 1 1/2" female fitting.
- 2) Fix the earth connection to the support.
- 3) Embed the support to get the platen at ground level.
- 4) Screw the waterfall and fix with the nuts (included).
 - a) Impulsion tube 2" (Ø63mm).
 - b) Self-priming pump:
AF-1: 1,5hp - 21,5m³/h (Ref.AQA-B21).
 - c) Suction tube 2" (Ø63mm).

*Pneumatic or electric button to be defined in work.

**AQA recommends to install a POOL PROTECTOR, to avoid corrosion of the existing stainless steel elements in the pool.