

REF. 2



Waterfall in stainless steel AISI 316L
(Marine quality) and fiberglass structure.
Polished finish.



Support
Included



Earth
Connection

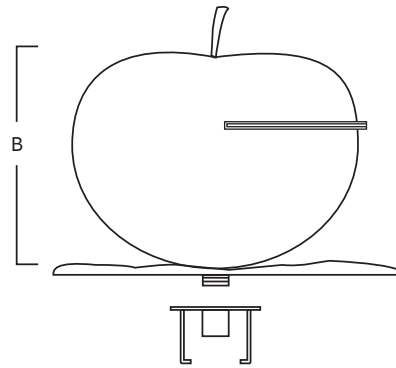
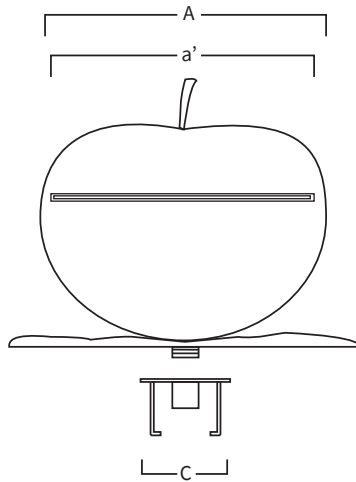

A	a'	B	C
450	460	500	Ø190

Measure in mm

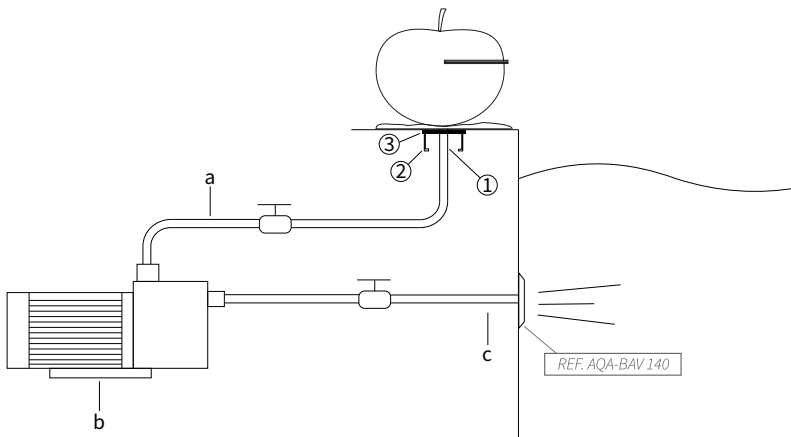

MOUNTING SYSTEM:

- 1) Connect the water intake to the support with 1 1/2" female fitting.
- 2) Fix the earth connection to the support.
- 3) Embed the support and screw the waterfall.
 - a) Impulsion tube 2" (Ø50mm).
 - b) Self-priming pump:
2: 0,80hp - 10m³/h (Ref. AQA-B10).
 - c) Suction tube 2" (Ø63mm).

*Pneumatic or electric button to be defined in work.