



REF. 115

Wall cannon in stainless steel
AISI 316L (Marine quality).
Polish finish.

A	B	C	D
115	125	130	Ø63x1,5
04,53	04,92	05,12	Ø2,48x0,06

Measure in mm
Measure in inch

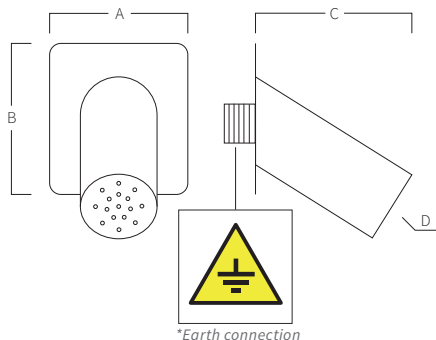

*Earth connection



REF. 116

Wall cannon in stainless steel
AISI 316L (Marine quality).
Polish finish.

A	B	C	D
115	125	190	Ø63x1,5
04,53	04,92	07,48	Ø2,48x0,06

Measure in mm
Measure in inch

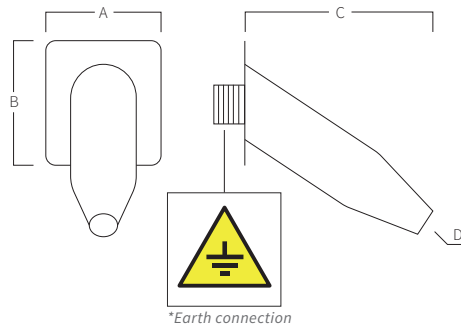

*Earth connection



REF. 117

Wall cannon in stainless steel
AISI 316L (Marine quality).
Polish finish.

A	B	C	D
115	125	195	Ø63x1,5
04,53	04,92	07,68	Ø2,48x0,06

Measure in mm
Measure in inch

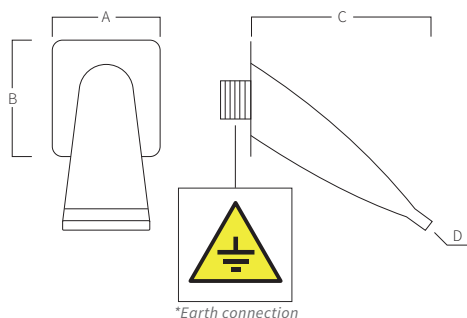

*Earth connection



REF. 122

Wall cannon in stainless steel
AISI 316L (Marine quality).
Polish finish.

A	B	C	D
115	125	140	Ø63x1,5
04,53	04,92	05,51	Ø2,48x0,06

Measure in mm
Measure in inch

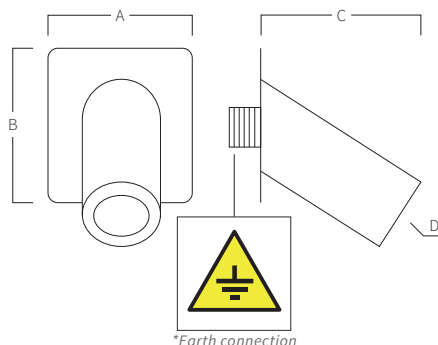

*Earth connection

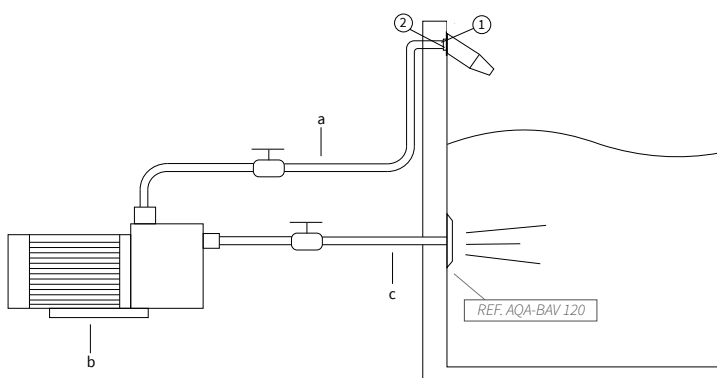

MOUNTING SYSTEM

- 1) Screw at the wall with 1 1/2" male fitting.
- 2) Connect the earth connection.
 - a) Impulsion tube Ø50mm.
 - b) Self-priming pump:
0,80hp - 10,5m³/h (Ref. AQA-B10).
 - c) Suction tube 2" (Ø63mm).

*Pneumatic or electric button to be defined in work.