

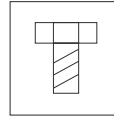

# REF. 112A

Waterfall in stainless steel AISI 316L  
(Marine quality). Polish finish.



Screws  
Included  
(4 units)

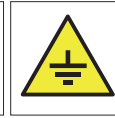

Earth  
Connection

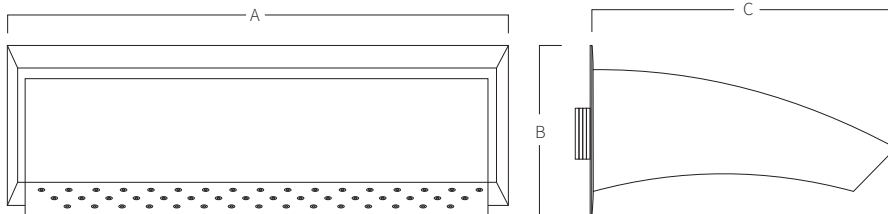

A	B	C
300 11,81	140 05,51	250 09,84
500 19,69	140 05,51	250 09,84
700 27,56	140 05,51	250 09,84
1000 39,37	140 05,51	250 09,84

Measure in mm  
Mesure in inch

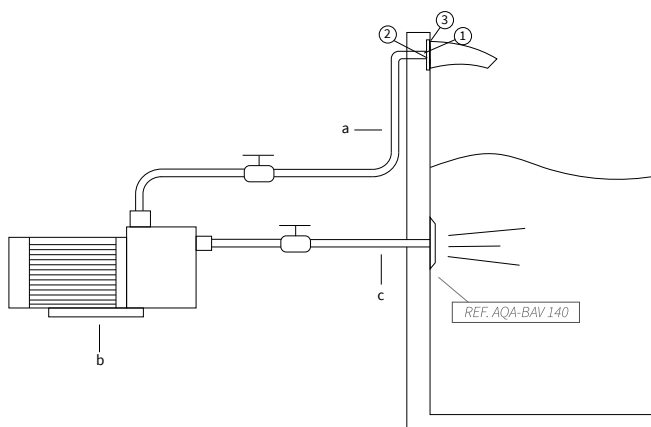

## MOUNTING SYSTEM

- 1) Screw at the wall with a 1 1/2" male fitting (width 300/500) and 2" male fitting (width 700/1000).
- 2) Connect the earth connection.
- 3) Fix with the 4 screws.
  - a) Impulsion tube Ø50mm (width 300/500) and Ø63mm (width 700/1000).
  - b) Self-priming pump:
    - 112A (300) 0,50hp - 8m<sup>3</sup>/h (Ref. AQA-B8).
    - 112A (500) 0,80hp - 10m<sup>3</sup>/h (Ref. AQA-B10).
    - 112A (700) 1hp - 17,3m<sup>3</sup>/h (Ref. AQA-B17)
    - 112A (1000) 1,5hp - 21,5m<sup>3</sup>/h (Ref. B21).
  - c) Suction tube 2" (Ø63mm).

\*Pneumatic or electric button to be defined in work.