



REF. 106.2

Waterfall in stainless steel AISI 316L
(Marine quality). Polish or satin finish.



Support
Included

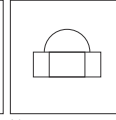

Nuts
Included
(3 units)

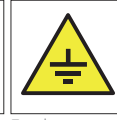

Earth
Connection

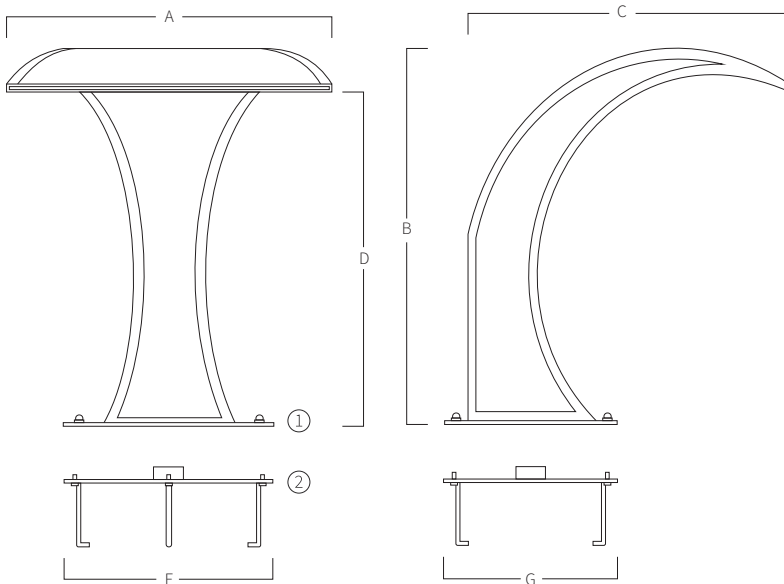

A	B	C	D	F	G
300 11,81	800 31,50	745 29,33	560 22,05	280 11,02	400 15,75
500 19,69	800 31,50	720 28,35	660 25,99	450 17,72	370 14,57
700 27,56	800 31,50	680 26,77	730 28,75	450 17,72	370 14,57
1000 39,37	1000 39,37	750 29,53	950 37,40	530 20,87	515 20,28

Measure in mm
Measure in inch

- ① Nuts to fix waterfall.
- ② Support to embed in the ground level.

MOUNTING SYSTEM

- 1) Connect the water intake to the support with 2" female fitting.
- 2) Fix the earth connection to the support.
- 3) Embed the support to get the platen at ground level.
- 4) Fix the waterfall with the nuts.
 - a) Impulsion tube 2" (Ø63mm).
 - b) Self-priming pump:
 - 106.2 (300) 1hp - 17,3m³/h (Ref. AQA-B17).
 - 106.2 (500) 1,5hp - 21,5m³/h (Ref. AQA-B21).
 - 106.2 (700) 2hp - 26,6m³/h (Ref. AQA-B26).
 - 106.2 (1000) 3hp - 38,8m³/h (Ref. AQA-B38).
 - c) Suction tube 2" (Ø63mm).

*Pneumatic or electric button to be defined in work.

